

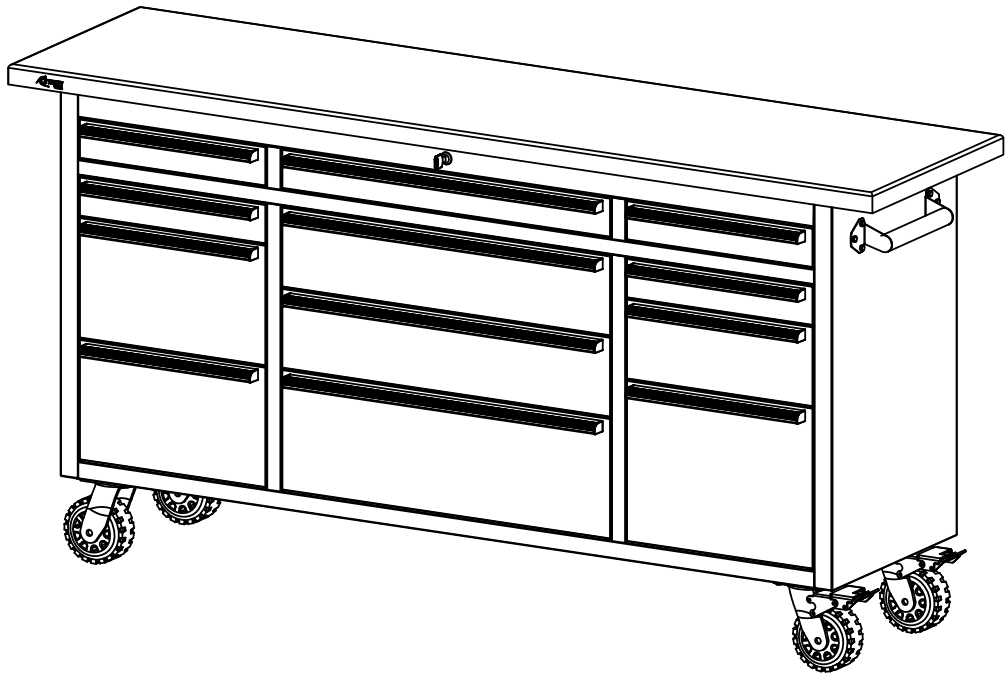

OWNER'S MANUAL



TRINITY PRO 72" 12-DRAWER STAINLESS STEEL ROLLING WORKBENCH Model # TLSF-7209



Important / Important / Importante

FOR QUICK & EASY 3D ASSEMBLY INSTRUCTIONS

POUR DES DIRECTIVES D'ASSEMBLAGE 3D RAPIDES ET FACILES

PARA INSTRUCCIONES DE ENSAMBLAJE RÁPIDAS Y SENCILLAS EN 3D

BILT.[®]

Intelligent Instructions
Directives intelligentes
Instrucciones Inteligentes



PARTS LIST

Your TRINITY PRO 72in 12-Drawer Stainless Steel Workbench should include the following parts. Please inspect box contents to ensure you have received all components.

If you are missing any parts, need assistance with assembly or have questions, please contact TRINITY Customer Service: 800.985.5506 or customerservice@trinityii.com. Parts can also be requested online via "Contact Us" section at www.trinityii.com.

You will need 14mm wrench (for casters) for assembly. This is NOT included.

A

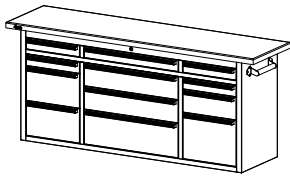

WORKBENCH (1)

B

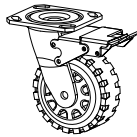

**LOCKING
CASTER (2)**

C



**NON-LOCKING
CASTER (2)**

D



**CASTER BOLT (16)
M10**

E

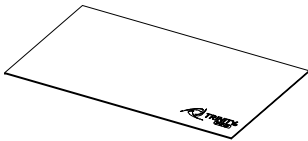

LINER (12)

F



KEY (2)

ASSEMBLY INSTRUCTIONS

STEP 1

Location of parts:

- 1) KEYS (F) are hooked to the key leash that is mounted in the TOP MIDDLE Drawer.
- 2) 2) CASTERS (B/C) and CASTER BOLTS (D) are boxed and put in the BOTTOM LEFT Drawer.
- 3) LINERS (E) are in the BOTTOM RIGHT Drawer

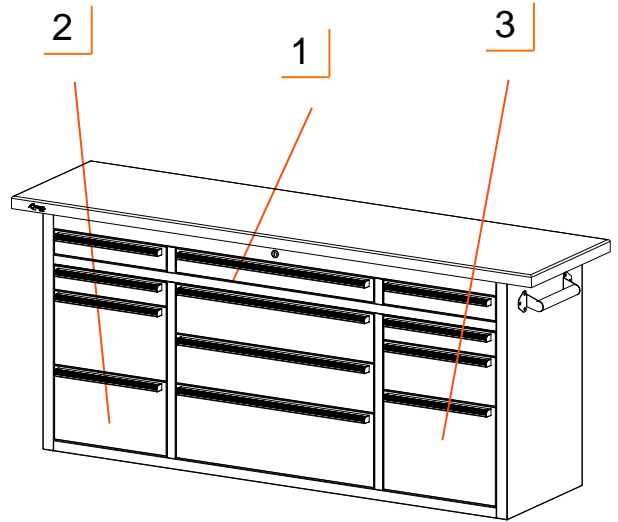

STEP 2

Lay WORKBENCH (A) on its backside. Lift workbench by side handles. Do NOT lift workbench by the wood top. Two people are needed. Do NOT attempt this alone.

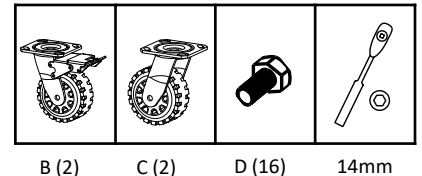

Position LOCKING CASTERS (B) on side of WORKBENCH (A) of your choice and align holes to pre-installed nuts on underside of WORKBENCH (A). Use a 14mm socket wrench to fully tighten CASTER BOLT (D) to WORKBENCH (A).

Repeat above steps to install NON-LOCKING CASTERS (C).

Notes:

- * Make sure to install both LOCKING CASTERS (B) on same side of workbench.
- ** For ease of use, place LOCKING CASTERS (B) on side you will regularly push or pull.
- *** If you plan to push the workbench against a wall, place LOCKING CASTERS (B) on front long side for ease of access.

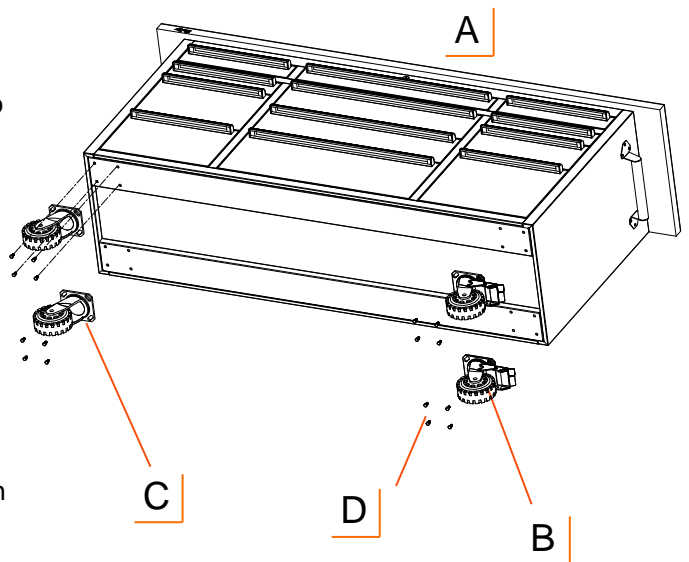

ASSEMBLY INSTRUCTIONS

STEP 3

Place LINERS (E) in each drawer.

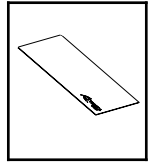

E (12)

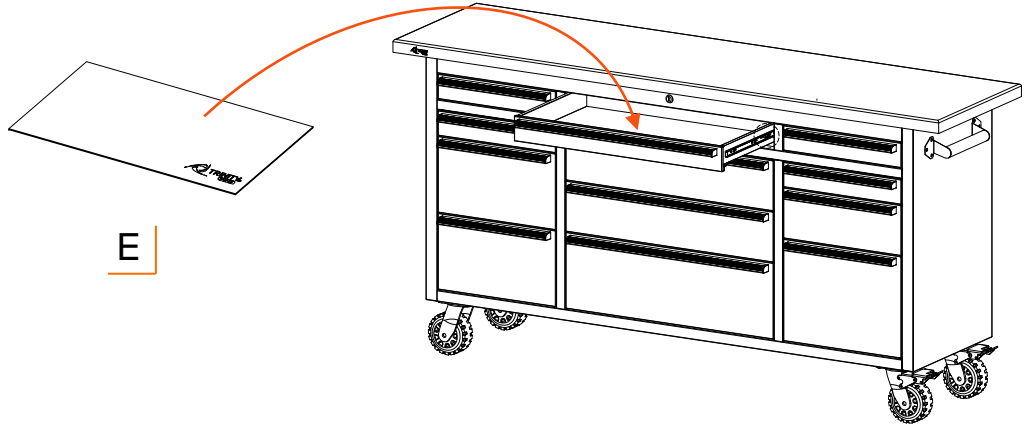

E

USAGE INSTRUCTIONS

DRAWER REMOVAL

Pull drawer out so that it is almost fully extended. On RIGHT-hand side, pull black release lever UP. On LEFT-hand side, push black release lever DOWN. While holding levers as instructed, pull drawer forward until released from the slides attached to Workbench (“Workbench Slides”).

Note: The slides attached to drawer (“Drawer Slides”) are an integral part of drawer and must be removed along with drawer itself.

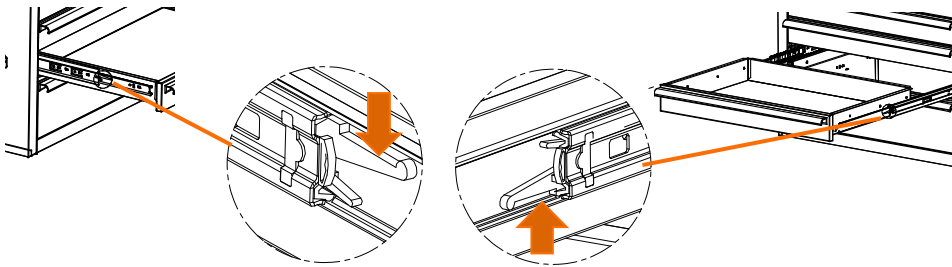

DRAWER REPLACEMENT

To replace drawer, pull slides out completely. Insert brackets on each side of Drawer Slides into corresponding slots on the Workbench Slides, making sure they are properly positioned. Once the brackets are inserted into the slots, completely close the drawer to set all slides in their proper positions.

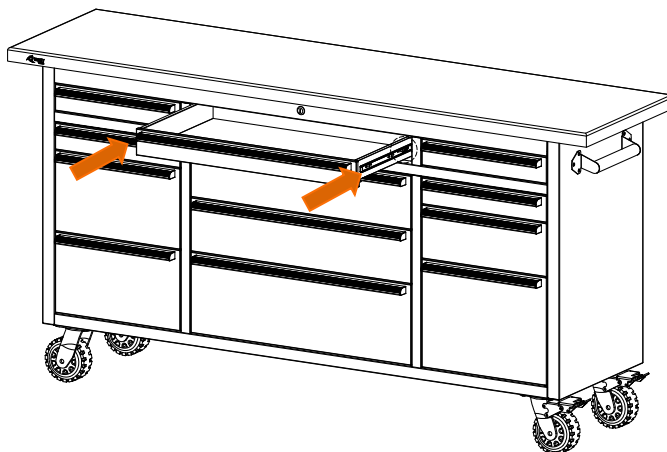

SERVICE PARTS LIST – TLSF-7209

TRINITY Customer Service provides the following replacement parts:

Part Number	Description	Part Number	Description
1) LNA-06-013-7219	Wood Top	13) XBK-22-006-2615	27" Drawer Liner
2) ZSV-01-001-0612	Handle Bolt	14) ZSV-99-028-5020	Non-locking Caster
3) XSV-05-001-0900	Side Handle	15) XBS-07-009-2709	27" Large Drawer
4) ZSV-12-015-1575	Slide (workbench side)	16) AMA-05-007-2600	27" Drawer Handle
5) ZSV-12-001-1575	Slide (drawer side)	17) XBS-07-009-2706	27" Medium Drawer
6) XBS-07-009-1506	15" 1 st Medium Drawer	18) XBK-23-010-3012	End cap
7) XBS-07-009-1512	15" Large Drawer	19) XBS-07-009-1509	15" 2 nd Medium Drawer
8) ZSV-01-001-1020	Caster Bolt	20) AMA-05-007-1400	15" Drawer Handle
9) ZSV-99-027-5020	Locking Caster	21) XBS-07-009-1503	15" Small Drawer
10) XBK-10-003-0XXX	Key	22) XBS-07-009-2703	27" Small Drawer
11) XBK-02-047-0001	Key leash	23) CSV-11-005-0XXX	Lock
12) XBK-22-006-1415	15" Drawer Liner		

NOTE: Replacement keys may be ordered using the code shown on the face of the lock.

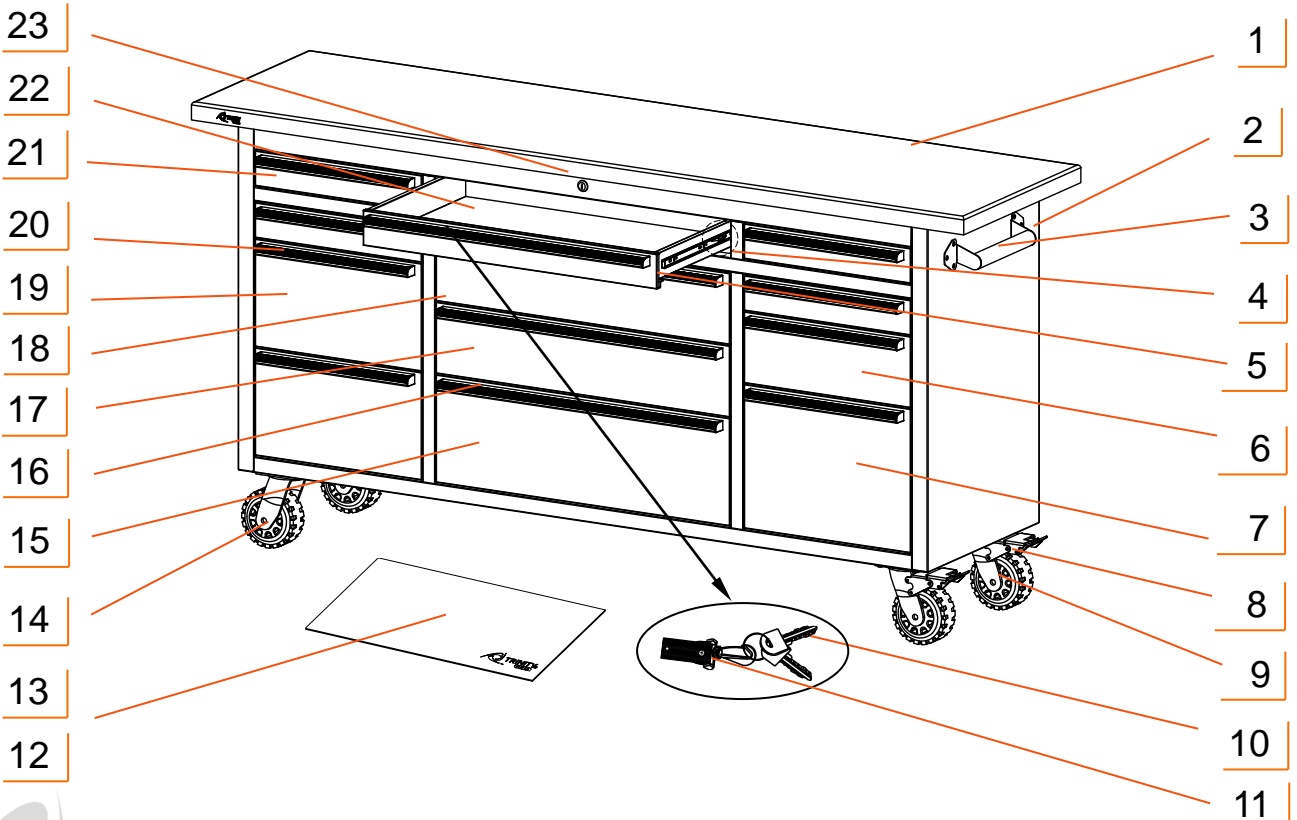

WARNINGS

1. **Read and understand all instructions.** Failure to follow all instructions may result in injury and/or damage.
2. **The warnings, cautions, and instructions discussed in this manual cannot cover all possible conditions or situations that may occur.** The user must always be aware of their environment and ensure that they use the product in a safe and responsible manner.
3. **Do NOT modify the product in any way.** Unauthorized modification may impair the function and/or safety of the product, and may affect the life of the product.
4. **Check for damaged parts.** Before using this product, carefully check that all parts are in good condition, and that the product will operate properly and perform its intended function. Check for damaged parts and any other conditions that may affect the operation of this product. Replace damaged or worn parts, and never use this product with a damaged part.
5. **Do NOT overload the product.**

Weight capacity per drawer w/ 1 pair of slides	100 lb
Weight capacity per drawer w/ 2 pairs of slides	200 lb
Total weight capacity of workbench	2200 lb

6. **Lock the casters when leaving workbench in stationary position.**
7. **Lock the drawers before moving the workbench.**
8. **Do NOT open more than one drawer at a time.** Tipping can occur.
9. **Do NOT step or lean on open drawers.** Tipping can occur.
10. **Do NOT lift workbench by wood top.** Wood top may separate causing injury.
11. **Do NOT let children play near workbench.**
12. **Load the workbench starting with the bottom drawers to prevent workbench from tipping.**
13. **Make sure all drawers are closed tightly before locking or unlocking.**

CARE AND MAINTENANCE

- Avoid harsh, abrasive cleaners, and other corrosive chemicals.
- Do not use scouring pad for cleaning.
- Keep dry and avoid damp environments.
- Use a quality stainless steel cleaner and follow instructions that come with the cleaner.
Wipe ALONG the grain (NOT against).
- Wood top can be cleaned with damp cloth and wiped dry immediately with dry cloth. If needed, solvent-based wood furniture cleaner can be used.
- Clean up any spills immediately to prevent stains from forming on the wood top.

PRODUCT REGISTRATION

Thank you for purchasing a TRINITY PRO 72in 12-Drawer Stainless Steel Rolling Workbench. In order to register your product and receive streamlined customer service, please fill out the following Product Registration Form and (1) fax the form to 310.347.4134 (2) complete the Product Registration Form online at www.trinityii.com or (3) scan and email the form to customerservice@trinityii.com. Include a copy of your original receipt with your submission.

First Name: _____ Last Name: _____

Address: _____

City: _____ State: _____ Zip Code: _____

Email Address: _____ Phone: _____

Product Model #: TLSF-7209 Purchase Date: ____ / ____ / ____

Location of Purchase: _____

Please rate the importance of each feature (1=least important; 10=most important)

Quality ____ Price ____ Size/Capacity ____ Appearance ____ Other ____

How did you hear about our product?

- Magazine Ad Catalog Salesperson Word of Mouth
 Internet Store Display Other

Marital Status: Single Married

Household Income: Below \$50,000 \$50,000-\$150,000 \$150,000+

Education: High School College Graduate School

Primary Residence: Own Rent

Comments/Suggestions:





1 YEAR LIMITED WARRANTY

TRINITY PRO 72" 12-Drawer Stainless Steel Rolling Workbench Model # TLSF-7209

Trinity International Industries ("Trinity") warrants to the original consumer purchaser ("Purchaser") of the TRINITY PRO 72in 12-Drawer Stainless Steel Rolling Workbench ("Product") that each Product shall be free from defects in workmanship and materials for a period of 1 year from the date of original purchase. Trinity's obligation under this warranty shall be limited to repair or replacement of, or adequate compensation for the Product which shall not be greater than the amount of the purchase price of the Product, at the option of Trinity, during the warranty period. All replaced parts and Products become the property of Trinity and must be returned to Trinity.

This warranty excludes normal wear and tear of the Product and its parts or components, and damage arising from any of the following: negligent use or misuse of the Product, use contrary to this User's Manual, or alteration by any one other than Trinity. The warranty period of 1 year shall not be extended or renewed by the repair or replacement of, or compensation for, the Product. Any warranty implied by applicable law is limited in duration to one year from the date of purchase and is subject to the same conditions and limitations as is provided for our express warranty.

Except as set forth herein, and to the extent of applicable there are no warranties on this Product either express or implied, and Trinity disclaims all warranties including, but not limited to, any implied warranties of merchantability, infringement or fitness for a particular purpose. No warranty or guarantee given by any person, firm, or corporation with respect to this product shall be binding on Trinity.

If your Product is defective or otherwise requires service or parts, please call TRINITY Customer Service toll-free at (800) 985-5506, between 5:00 a.m. and 5:00 p.m., PST. Please tell us which model you purchased, the date of the purchase, and the problem with your Product. A copy of your original purchase receipt must accompany your service request.

LIMITATION OF REMEDIES AND LIABILITY

Trinity (and its employees, officers, members, managers, affiliates and assigns) shall not be liable for any incidental, consequential, special, indirect, remote, special or punitive damages for breach of any warranty, express or implied, including, but not limited to, lost profits, lost savings, loss of anticipated benefits and attorneys' fees, which arise out of the purchase, use or inability to use the Product, whether arising out of contract, negligence, strict tort, product liability, or any other legal theory on which a claim is based. As noted above, to the extent damages are allowed by our express warranty or by applicable law, those damages may not exceed the purchase price paid for the Product. Without limiting the foregoing Purchaser assumes all risk and liability for loss, damage or injury to Purchaser and Purchaser's property and to others and their property arising out of the use, misuse, or inability to use this Product. This limited warranty shall not extend to anyone other than the original purchaser of this product, is nontransferable and states your exclusive remedy.

Some states do not allow the exclusion or limitation of incidental, consequential, special, or punitive damages, so the above limitation or exclusion may not apply to you. The above warranty gives you specific legal rights, and you may have other rights which vary from state to state.

CONTACT US

**QUESTIONS? NEED PARTS?
WE ARE HERE TO HELP!**

Please feel free to contact us. There are no questions too small, or any problems too big. We're committed to providing our customers with the highest level of service.

TRINITY Customer Service

TEL: 800.985.5506

FAX: 310.347.4134

EMAIL: customerservice@trinityii.com

**Monday through Friday
5:00 AM – 5:00 PM (PST)**

www.trinityii.com